

Clariflo®

X-PRO



RIGHT ANGLE SANDER

MODEL NO: CAT168

PART NO: 3120182

OPERATING & MAINTENANCE INSTRUCTIONS



ORIGINAL INSTRUCTIONS

GC0417

INTRODUCTION

Thank you for purchasing this CLARKE Right Angle Sander.

Before attempting to use this product, please read this manual thoroughly and follow the instructions carefully. In doing so you will ensure the safety of yourself and that of others around you, and you can look forward to your purchase giving you long and satisfactory service.

Please keep these instruction in a safe place for future reference.

SPECIFICATION

| Model Numbers | CAT168 |
|-------------------------------|-----------------------------------|
| Part Number | 3120182 |
| Min. Hose Size (ID) | 8 mm (5/16") |
| Operating Pressure | 90 psi (6.2 bar) |
| Air Consumption | 13 cfm (max load), - 4cfm nominal |
| Air Inlet Size | 1/4" BSP Female |
| Sound Pressure Level (LpA dB) | 85.8 dB(A) |
| Sound Power Level (LwA dB) | 96.8 dB(A) |
| Vibration Levels | 5.897 m/s ² |
| Vibration Uncertainty K | 1.5 |
| Weight | 0.7 kg |
| Speed Settings | |
| | 1 6,500 (+/- 10%) |
| | 2 9,500 (+/- 10%) |
| | 3 12,500 (+/- 10%) |
| | 4 15,000 (+/- 10%) |

Please note that the details and specifications contained herein are correct at the time of going to print. However CLARKE International reserve the right to change specifications at any time without prior notice

GENERAL SAFETY RULES



CAUTION: FAILURE TO FOLLOW THESE PRECAUTIONS COULD RESULT IN PERSONAL INJURY, AND/OR DAMAGE TO PROPERTY.

WORK ENVIRONMENT

1. Keep the work area clean and tidy.
2. Dress appropriately - Do not wear loose clothing or jewellery. Tie long hair out of the way.
3. Keep children and visitors away - Do not let children handle the tool.
4. Do not operate the tool where there are flammable liquids or gases.

USE OF AIR POWERED TOOLS

1. Stay alert and use common sense - do not operate this tool when you are tired or under the influence of alcohol, drugs or medication.
2. Always wear eye protectors when using air tools. Eye protectors must provide protection from flying particles from the front and the side.
3. Do not overreach - keep proper footing and balance at all times.
4. Never use oxygen, CO², combustible gasses, or any bottled gas, as a source of power for an air tool. This product should only be used with a suitably rated compressed air supply.
5. Do not connect the air hose with your finger on the trigger.
6. Do not fit the sander to any stand or clamping device that may damage it.
7. Do not exceed the maximum pressure for the tool of 7 bar.
8. Keep the air hose away from heat, oil and sharp edges.
9. Check hoses for leaks or excessive wear before use, and ensure that all connections are secure.
10. Do not use the sander for any other purpose than described in this manual.
11. Do not carry out any alterations or modifications to the tool.
12. Always disconnect from the air supply when:
 - Performing any maintenance.
 - The sander is not in use.
 - The sander will be left unattended.

- Moving to another work area.
 - Passing the sander to another person.
13. Never use the sander if it is defective or operating abnormally.
 14. Avoid damaging the sander by applying excessive force of any kind.
 15. Always maintain the sander with care. Keep it clean for the best and safest performance.
 16. ALWAYS ensure the workpiece is firmly secured.
 17. ALWAYS ensure the sander has stopped before putting it down after use.
 18. ALWAYS ensure that any attachments are correctly fastened before connecting the sander to the air supply.
 19. Do not force or misuse the sander. It will do a better and safer job at the rate for which it was designed.
 20. Quick change couplings should not be located at the air tool. They add weight and could fail due to vibration.
 21. This tool vibrates with use. Vibration may be harmful to your hands or arms. Stop using the tool if discomfort, a tingling feeling or pain occurs. Seek medical advice before resuming use.

SANDER-SPECIFIC SAFETY RULES

1. Inspect the sanding pad before use. Do not use if cracked or broken. Check if possible, that the rated speed of the backing pad is at least as high as that of the machine.
2. Avoid contact with the moving sanding pad and wear suitable gloves to protect the hands.
3. Never start the sander unless the abrasive pad is applied to the workpiece.
4. Beware of potentially explosive atmospheres being caused by dust / fumes resulting from sanding and use dust extraction systems where possible.
5. Always wear a face mask when using the sander as protection from airborne particles of sanded material. Avoid disturbing existing dust and minimise the scattering of dust in the workplace environment. Take steps to control the dust at the point of emission.

TRANSPORTATION

1. Never carry the sander by the air supply hose.
2. Never carry the sander with your finger on the trigger.

THE COMPRESSED AIR SUPPLY

AIR SUPPLY REQUIREMENTS



WARNING: COMPRESSED AIR CAN BE DANGEROUS. ENSURE THAT YOU ARE FAMILIAR WITH ALL PRECAUTIONS RELATING TO THE USE OF COMPRESSORS AND COMPRESSED AIR SUPPLY.

- Use only clean, dry, regulated compressed air as a power source.
- Air compressors used with the tool must comply with the appropriate European Community Safety Directives.
- A build-up of moisture or oil in the air compressor will accelerate wear and corrosion in the tool. ensure any moisture is drained from the compressor daily and the inlet filter is kept clean.
- If an unusually long air hose is required, (over 8 metres), the line pressure or the hose inside diameter may need to be increased.
- The air hose must be rated at least 150% of the maximum operating pressure of the air tool.

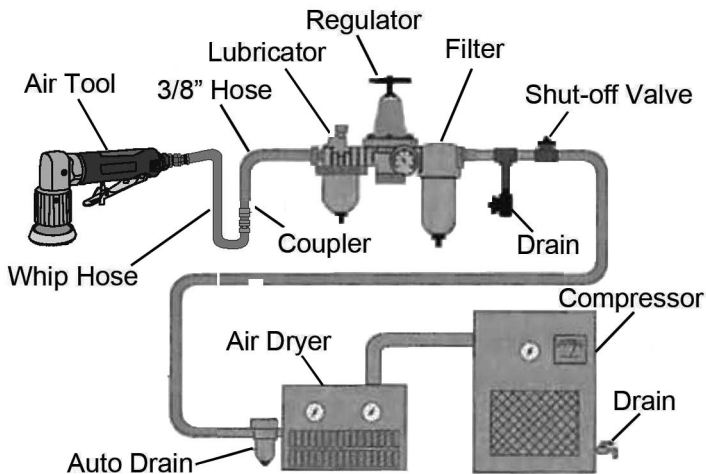

- A typical air line layout is shown above. If an automatic in-line filter/regulator is used, it will keep the tool in good condition, but should be regularly checked and topped up with oil. SAE 10 oil should be used and the lubricator adjusted to approx 2 drops per minute.
- The minimum hose diameter should be 5/16" (8mm) ID and fittings should have the same internal dimensions.

- Never exceed the maximum operating pressure for the tool. It is recommended that air pressure to this tool does not exceed 6.2 bar (90 psi) at the tool when running. Higher pressures and unclean air will shorten the life of the tool due to faster wear and is a possible safety hazard.

PRODUCT OVERVIEW

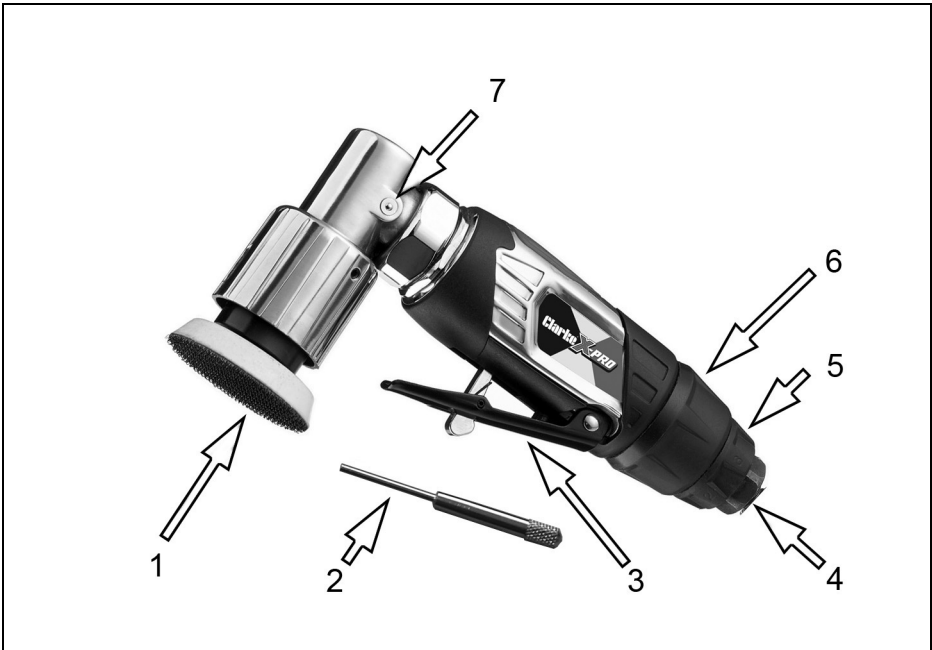

| NO | DESCRIPTION | NO | DESCRIPTION |
|----|--------------------|----|------------------------------|
| 1 | Sanding Pad | 5 | Air Exhaust Outlet/deflector |
| 2 | Drive Locking Tool | 6 | Speed Adjuster |
| 3 | Safety Trigger | 7 | Grease Nipple |
| 4 | Female air inlet | | |

BEFORE USE

FITTING/REMOVING THE SANDING PAD

1. Rotate the eccentric wheel by hand until the locking hole can be seen through the slot in the front housing.
2. Insert the drive locking tool into the hole to stop the drive from rotating.
3. Hold the drive locking tool firmly while screwing on the sanding pad clockwise. Make sure the sanding pad is tight and secure.
4. The pad can be removed by unscrewing anticlockwise.

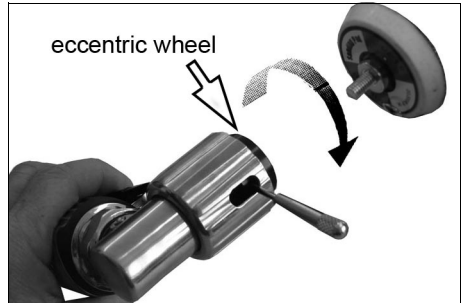

FITTING/REMOVING THE SANDING DISC

1. Fit the backing disc to the sander by locking the moving drive spindle with the key supplied and screwing the disc tightly into place.
2. Select the disc to be used which MUST be correct disc with hook and loop backing.
3. Press the disc firmly onto the pad to secure it.

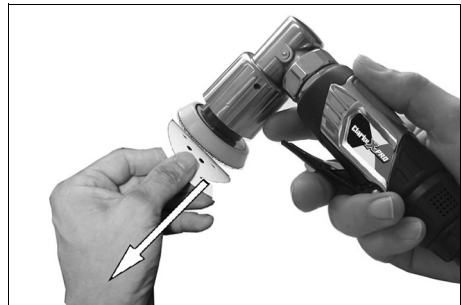

CONNECTING THE AIR SUPPLY



WARNING: COMPRESSED AIR CAN BE DANGEROUS. ENSURE THAT YOU ARE FAMILIAR WITH ALL PRECAUTIONS RELATING TO THE USE OF AIR COMPRESSORS AND A COMPRESSED AIR SUPPLY.

1. Connect one end of the hose to the compressed air supply.
2. Remove the protective plug from the air inlet and connect a suitable hose as shown.

3. Turn on the compressed air supply and check for air leaks. Rectify any found before proceeding.

- PTFE tape may be useful for sealing threaded connections.

4. If required, connect an in-line mini oiler to the sander. A mini oiler helps to prolong the life of the tool.

5. If a mini-oiler is not being used, run a few drops of oil through the sander before use. It can be entered through the airline inlet or via the hose at the nearest connection to the air supply.

6. A gauze filter is fitted inside the air inlet. Ensure this filter is always in place and is kept clean. An airline is connected to the adapter, preferably via a quick release coupling (not supplied).

7. Ensure the trigger is NOT depressed when connecting the air line.

- Your sander is now ready for use
- You can fit a whip hose with a quick fit coupling if required (available from your Clarke dealer.)

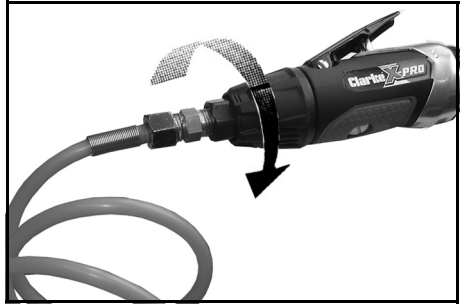

OPERATION

IMPORTANT: Only use abrasive sanding pads designed for use with this type of sanding pad.

1. To start, squeeze the trigger against the body of the sander.
2. Rest the sander on the workpiece before starting it. Let the sander do the work.

- The actual weight of the sander is normally sufficient for efficient sanding. Do not put additional pressure on the sander, which would only slow down the speed of the pad, reducing efficiency and placing an additional burden on the motor.

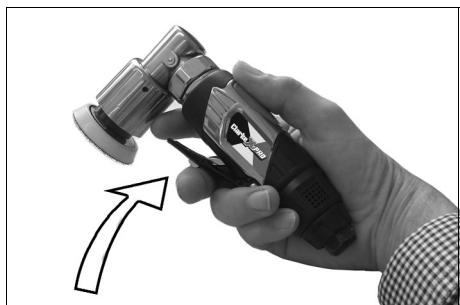

3. Pass the sander back and forth in wide, overlapping areas, taking care to keep the sander moving around at all times. Avoid dwelling in one place for more than a moment.

4. Release the trigger to stop the sander.
5. Set the speed by twisting the adjustable 4-speed regulator. The embossed number should line up with the mark on the air inlet to show the speed.
 - Speeds are stated in the specification on page 2.
6. Always ensure the sander has stopped before putting it down.

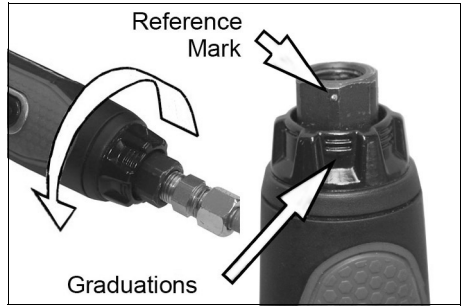

SETTING THE EXHAUST DEFLECTOR

The direction of the exhaust air leaving the tool can be adjusted by rotating the exhaust deflector.

1. Twist the exhaust deflector sleeve to direct the air as required to deflect air away from the workpiece or operator

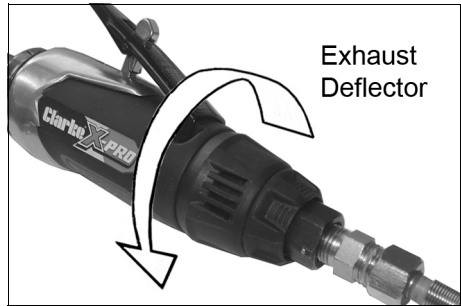

DISCONNECTING THE AIR SUPPLY

1. Do not disconnect the compressed air supply hose until the air supply has been shut down or isolated at the shut off valve and the compressed air expelled by running the tool until it stops.
2. Refer to the compressor instruction manual for the procedure to shut down and release the compressed air.
3. Once the pressure has been released, disconnect the air supply hose from the sander.

MAINTENANCE



WARNING: MAKE SURE THAT THE SANDER IS DISCONNECTED FROM THE AIR SUPPLY BEFORE STARTING ANY CLEANING, OR MAINTENANCE PROCEDURES.

Please note that factors other than the tools condition may effect its operation and efficiency, such as reduced compressor output, excessive drain on the airline, moisture or restrictions in the air-line, or the use of connectors of improper size or poor condition which will reduce air supply.

DAILY OR EVERY USE

1. Before use, drain water from the air-line and compressor.
2. Lubricate the sander daily or before each use for optimum performance. Use a high quality airline oil either via a lubricator in the air supply system or by placing a few drops into the air inlet immediately before use. This should be carried out regardless of whether or not an in-line lubricator is used.
3. Keep the sander clean and free from debris.

CLEANING & OVERHAULING

1. The right angle drive is fitted with a grease nipple to provide a facility for lubrication of the drive gears. After extensive use, apply a shot of general purpose grease using a suitable grease gun.
2. Grit or gum deposits in the mechanism may eventually reduce efficiency. This condition can be corrected by cleaning the air inlet filter and flushing out the tool with gum solvent oil or an equal mixture of SAE No10 oil and paraffin. Allow the mixture to soak into the moving parts before draining off the excess.

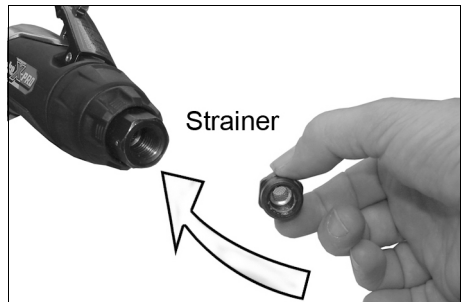

3. Failing this, it may be necessary to replace worn or damaged parts. You may prefer to take the tool to your Clarke dealer if internal maintenance is required.

STORAGE

If the tool is to be stored or is idle for longer than 24 hours, run a few drops of Clarke air-line oil into the air inlet and depress the trigger in order to lubricate the internal parts.

When not in use, the tool should be disconnected from the air supply and stored in a dry place out of the reach of children. Avoid storing in a damp environment.

ABRASIVE DISCS

Replacement hook and eye backed abrasive discs (2" (50mm) dia) are available from your CLARKE dealer:

| | | |
|--------|----------|-----------------|
| CAT173 | 60 grit | Part No 3120190 |
| CAT174 | 120 grit | Part No 3120191 |
| CAT175 | 180 grit | Part No 3120192 |

GUARANTEE

This product is guaranteed against faulty manufacture for a period of 12 months from the date of purchase. Please keep your receipt which will be required as proof of purchase.

This guarantee is invalid if the product is found to have been abused or tampered with in any way, or not used for the purpose for which it was intended.

Faulty goods should be returned to their place of purchase, no product can be returned to us without prior permission.

This guarantee does not effect your statutory rights.

TROUBLESHOOTING

| SYMPTOM | PROBLEM | SOLUTION |
|--|---|--|
| Tool runs at normal speed but slows down under any load. | <ol style="list-style-type: none"> 1. Excessive pressure on the sander. 2. Motor parts worn. 3. Worn or sticking mechanism due to lack of lubricant. | <ol style="list-style-type: none"> 1. Reduce the force applied to the sander. 2. Return to Clarke dealer for repair. 3. Drip air tool lubricating oil into air inlet. Allow oil to soak moving parts before using. |
| Tool runs slowly. Air flows weakly from exhaust. | <ol style="list-style-type: none"> 1. Motor parts jammed with gum/dirt. 2. Regulator in closed position. 3. General airflow blocked by dirt. | <ol style="list-style-type: none"> 1. Examine inlet air filter for cleanliness. 2. Adjust regulator to open position. 3. Operate tool in short bursts. |
| Tool will not run. Air flows freely from exhaust. | <ol style="list-style-type: none"> 1. Motor vanes stuck due to buildup of foreign material. | <ol style="list-style-type: none"> 1. Disconnect air supply and rotate tool assembly manually. 2. Try operating tool in short bursts. 3. Tap motor housing gently with a rubber mallet. 4. Drip a few drops of air tool lubricating oil into air inlet to soak moving parts. |
| Tool will not shut off. | <ol style="list-style-type: none"> 1. O-rings damaged or ill-fitting in seat. | <ol style="list-style-type: none"> 1. Return to Clarke dealer for repair. |

AIRLINE ACCESSORIES AND CONSUMABLES

A wide range of airline accessories is available including filter/regulators, lubricators, high-pressure hoses (5 to 50 metres) etc. Contact your Clarke dealer or Clarke International Service Department for further information.

Clarke Air-Ine Oil (Part no. 3050825) is available from your Clarke dealer.

PARTS DIAGRAM

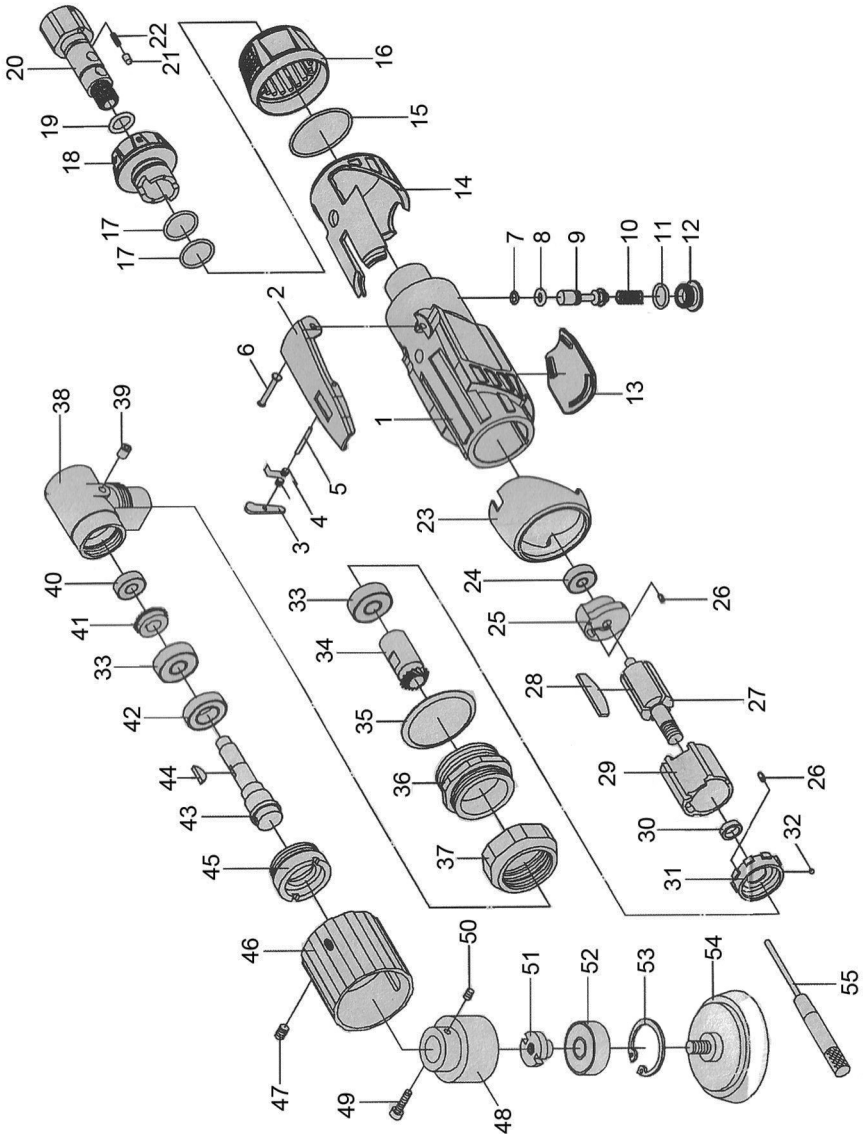

PARTS LIST

| No | Description |
|----|---------------|
| 1 | Main Housing |
| 2 | Trigger |
| 3 | Lever Block |
| 4 | Spring |
| 5 | Bolt |
| 6 | Bolt |
| 7 | O-ring |
| 8 | O-ring |
| 9 | Valve Stem |
| 10 | Spring |
| 11 | O-ring |
| 12 | Screw Nut |
| 13 | Rubber Cover |
| 14 | Rear Cover |
| 15 | O-ring |
| 16 | Muffler |
| 17 | O-ring |
| 18 | Air Regulator |
| 19 | O-ring |
| 20 | Air Inlet |
| 21 | Pin Sleeve |
| 22 | Spring |
| 23 | Front Cover |
| 24 | Bearing |
| 25 | Rear Plate |
| 26 | Bolt |
| 27 | Rotor |
| 28 | Rotor Blade |

| No | Description |
|----|-----------------------|
| 29 | Cylinder |
| 30 | Bushing |
| 31 | Front Plate |
| 32 | Steel Ball |
| 33 | Bearing |
| 34 | Major Gear |
| 35 | Cushion |
| 36 | Securing Ring |
| 37 | Set Nut |
| 38 | Right Angle Casing |
| 39 | Grease Nipple |
| 40 | Bearing |
| 41 | Gear |
| 42 | Bearing |
| 43 | Spindle |
| 44 | Woodruffe Key |
| 45 | Fixing Ring |
| 46 | Front Housing |
| 47 | Set Screw |
| 48 | Eccentric Drive Wheel |
| 49 | Screw |
| 50 | Screw |
| 51 | Bearing Seat |
| 52 | Bearing |
| 53 | Circlip |
| 54 | Sanding Pad |
| 55 | Drive Locking Tool |
| | |

DECLARATION OF CONFORMITY



Clarke[®]
INTERNATIONAL

Hemnal Street, Epping, Essex CM16 4LG

DECLARATION OF CONFORMITY

This is an important document and should be retained.

We hereby declare that this product(s) complies with the following directive(s):

2006/42/EC Machinery Directive.

The following standards have been applied to the product(s):

EN ISO 11148-08:2011.

The technical documentation required to demonstrate that the product(s) meet(s) the requirement(s) of the aforementioned directive(s) has been compiled and is available for inspection by the relevant enforcement authorities.

The CE mark was first applied in: 2017

Product Description: Right Angle Air Sander
Model number(s): CAT168
Serial / batch Number: N/A
Date of Issue: 07/03/2017

Signed:

J.A. Clarke
Director

A SELECTION FROM THE VAST RANGE OF

Clarke®

QUALITY PRODUCTS

AIR COMPRESSORS

From DIY to industrial, Plus air tools, spray guns and accessories.

GENERATORS

Prime duty or emergency standby for business, home and leisure.

POWER WASHERS

Hot and cold, electric and engine driven - we have what you need

WELDERS

Mig, Arc, Tig and Spot. From DIY to auto/industrial.

METALWORKING

Drills, grinders and saws for DIY and professional use.

WOODWORKING

Saws, sanders, lathes, mortisers and dust extraction.

HYDRAULICS

Cranes, body repair kits, transmission jacks for all types of workshop use.

WATER PUMPS

Submersible, electric and engine driven for DIY, agriculture and industry.

POWERTOOLS

Angle grinders, cordless drill sets, saws and sanders.

STARTERS/CHARGERS

All sizes for car and commercial use.



PARTS & SERVICE: 0208 988 7400

E-mail: Parts@clarkeinternational.com or Service@clarkeinternational.com

SALES: UK 01992 565333 or Export 00 44 (0)1992 565335

Clarke® INTERNATIONAL Hemnall Street, Epping, Essex CM16 4LG
www.clarkeinternational.com